

# RP0911

## Rotary Potentiometer

The RP09 is a high performance rotary potentiometer sensor designed for the most demanding control and measurement systems. They are used extensively in motorsport for throttle and gearbox control, steering angle measurement and the monitoring systems of the chassis and also industrial applications such as valve position feedback.

The sensor has a stainless steel operating shaft set within 'twin' stainless steel ball-race bearings.

Models available have a choice of mounting and shaft options and electrical angles up to 350°.

### Other models in this range

- RP0921 - Servo mount (duplex)
- RP0931 - Servo mount (triplex)
- RP0912 - Triangular flange (single)
- RP0922 - Triangular flange (duplex)
- RP0932 - Triangular flange (triplex)
- RP0913 - Flange mount (single)
- RP0923 - Flange mount (duplex)
- RP0933 - Flange mount (triplex)

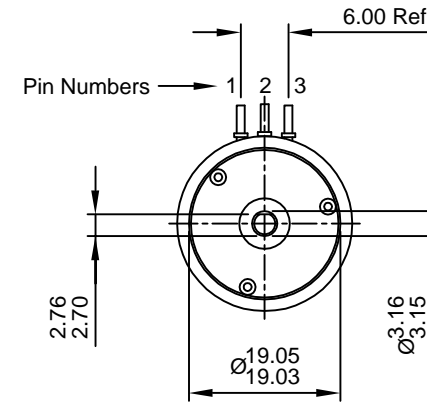
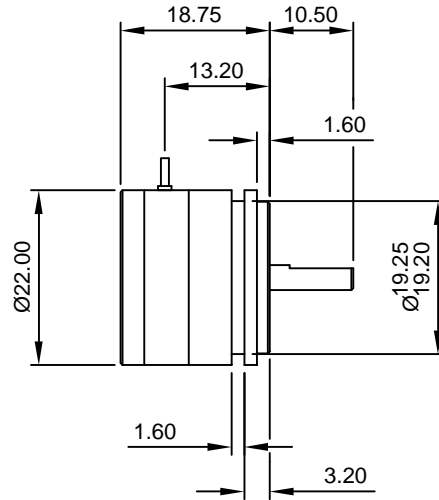

### Electrical & Mechanical Information

Electrical angle	350°	130°	100°	
Resistance (Typical)	3	1	1	K ohms
Non-linearity	<±0.30	<±0.50	<±0.50	%
Applied voltage	<42	<20	<15	Volts
Maximum wiper current	1			mA
Mechanical travel	360° continuous			
Insulation resistance (at 500V dc)	>100			M ohms
Operating temp. range	-55° to +125°			°C
Sealing	IP50			
Weight (approx.)	15			grams
Case material	Aluminium 6262			
Shaft material	Stainless Steel 303 series			
Shaft bearing	AISI 440c Martensitic Stainless Steel (NMB DDRIF-418ZZ)			

Note 1: When shaft flat is facing terminal pin 2, instrument is mid-travel. Note 2: Incorrect wiring may cause internal damage. Circuit recommendation: Due to the presence of a high contact resistance, these potentiometers should be used as voltage dividers only. Operation with wiper circuits of low impedance will degrade the output signal.

### Electrical Connections (See Note 2)

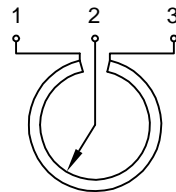

Schematic view on shaft

### Ordering Information

RP0911-XXX

Electrical angle in degrees

Active  
sensors

sales@activesensors.com