

**LT0600 Series - LVDT position sensor (5mm to 60mm measurement range)**  
 Ø6mm Pencil-slim, ultra-compact body

**Dimensions for LT0601-1-XX**

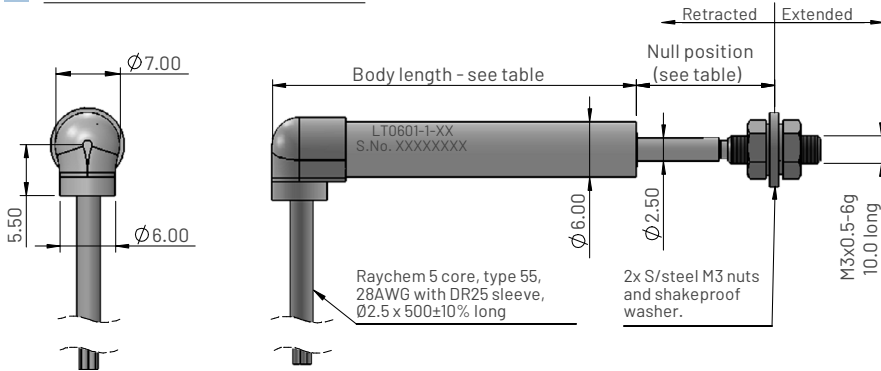

Ordering code

LT0601-1-XX

Measurement range in mm

**Dimensions for LT0607-1-XX**

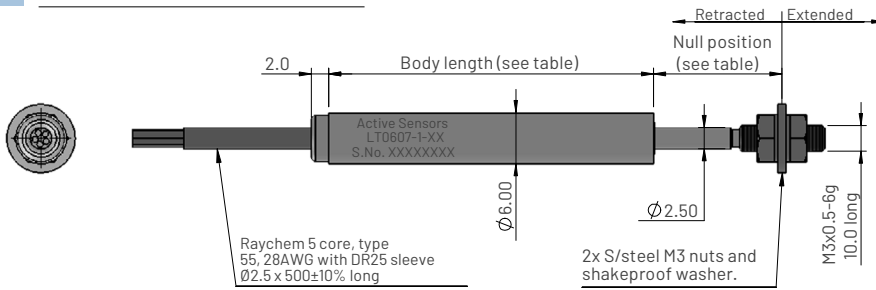

Ordering code

LT0607-1-XX

Measurement range in mm

**Dimensions for LT0602-1-XX**

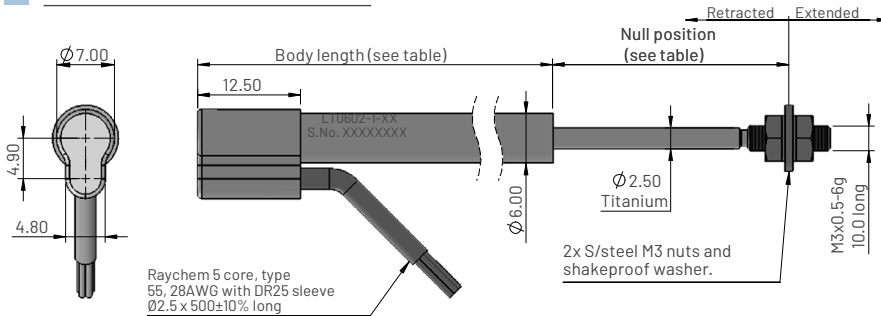

Ordering code

LT0602-1-XX

Measurement range in mm

**Electrical and mechanical specification**

Parameters	Values							Units	Tol	Notes
	05	10	15	25	40	50	60			
Measurement range (MR)	05	10	15	25	40	50	60	mm		
Electrical stroke	±2.5	±10.0	±7.5	±12.5	±20.0	±25.0	±30.0	mm		
Mechanical stroke	±3.5	±11.0	±8.5	±13.5	±21.0	±26.0	±31.0	mm	Max	
Body length LT0601	39.5			57.6	70.6	80.6	92.6	mm	±0.5	
Body length LT0607	38.0			56.3	69.3	79.3	91.3	mm	±0.5	
Body length LT0602	-	-	-	55.0	68.0	78.0	90.0	mm	±0.5	
Null position (mid position)	10.0	12.5	15.0	21.2	28.7	33.7	38.7	mm	±1.0	
Input voltage (Ve)	3.0							Vrms	±5%	1
Input frequency	5000							Hz	±5%	
Non-linearity	<±0.5			<±0.3				% FS		3, 6
Ratiometric sensitivity	0.0546	0.0546	0.0547	0.0361	0.0253	0.0203	0.0158	R/mm	±3%	2, 3
Va and Vb voltage range	0.604 - 0.794	0.506 - 0.886	0.414 - 0.990	0.708 - 1.872	0.571 - 1.742	0.524 - 1.603	0.621 - 1.740	Vrms	Nom	4, 5
(Va + Vb)/Ve Summation ratio	0.466	0.464	0.468	0.860	0.771	0.709	0.787	Vrms/Ve	±20%	
Thermal drift	<±0.015			<±0.005				%FS/°C		6, 7
Input impedance	>150			>120				Ohms		
Insulation resistance	>100			>100				Mohms		8
Operating temperature range	-55 to +135							°C		
IP rating	IP67									
Weight (excluding cable)	5			8	10	11	14	grams	Nom	
Materials	Housing - Stainless steel 416, Shaft - Stainless steel 316									

**Notes**

1. Sine waveform. THD <3%.
2. Ratiometric measurement mode (R) is defined as (Va-Vb)/(Va+Vb).
3. Non-linearity error and ratiometric sensitivity is calculated by least squares best fit method.
4. Va and Vb are ratiometric with Ve.
5. Blue (Va) increases and Yellow (Vb) decreases as shaft extends (as shown in Output schematic).
6. FS is defined as ratiometric sensitivity x measurement range (MR).
7. Average thermal drift over operating temperature range.
8. Between prim and sec coils and all coils to case at 500Vdc.

**LVDT AC Output schematic**

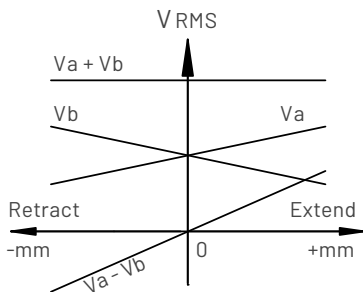

**Electrical connections**

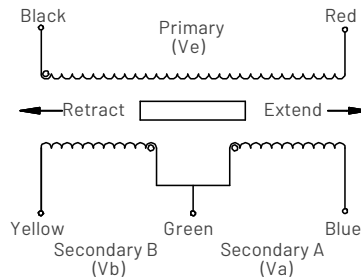

**Europe**  
 Active Sensors Ltd,  
 Unit 12, Wilverley Road,  
 Christchurch, Dorset,  
 BH23 3RU, UK

**North America**  
 Active Sensors Inc,  
 8520 Allison Pointe Blvd, Suite 220,  
 Indianapolis,  
 IN 46250, USA