

MHR5100 CE Series - Magnetic-Hall rotary position sensor

General-purpose series, Encoder output

Dimensions for MHR511X CE - Flange mounting, sprung shaft

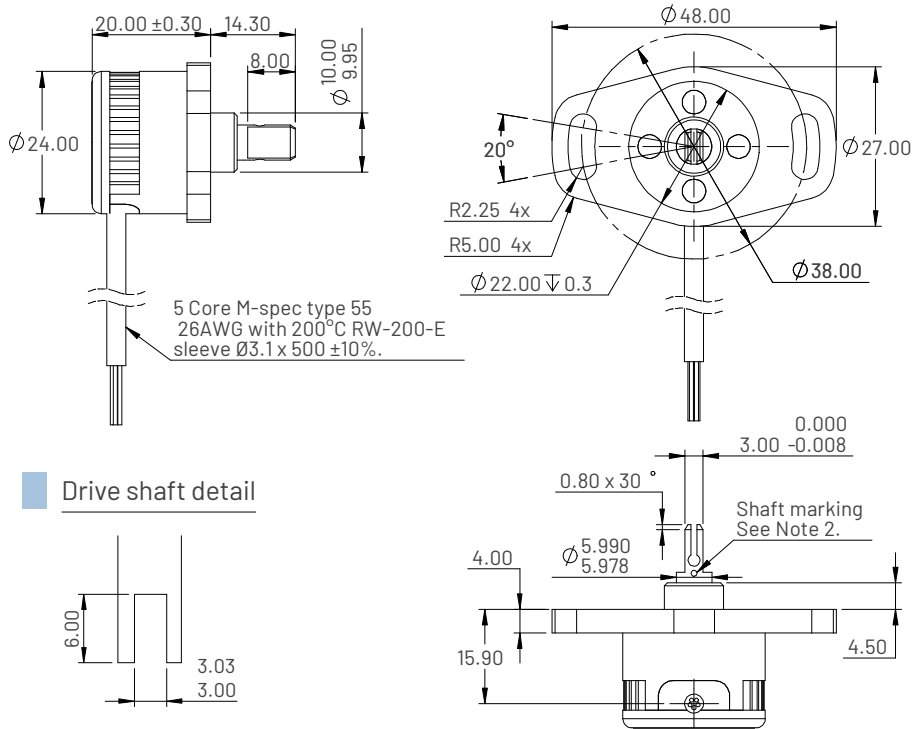

Ordering information

MHR511X CE

- Heatshrink boot _____
- 0 = Unbooted
- 1 = Heatshrink boot
- Output direction (viewed on shaft) _____
- C = Clockwise

Dimensions for MHR512X CE - Flange mounting, sprung shaft

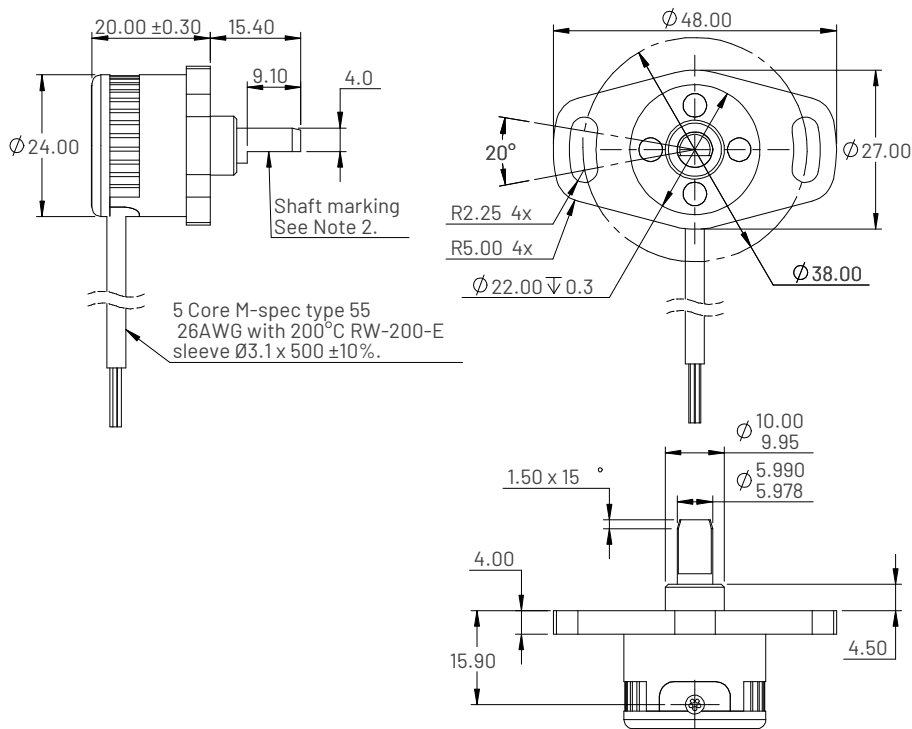

Ordering information

MHR512X CE

- Heatshrink boot _____
- 0 = Unbooted
- 1 = Heatshrink boot
- Output direction (viewed on shaft) _____
- C = Clockwise

MHR5100 CE Series - Magnetic-Hall rotary position sensor

General-purpose series, Encoder output

Dimensions for MHR513X CE - Flange mounting, blade shaft

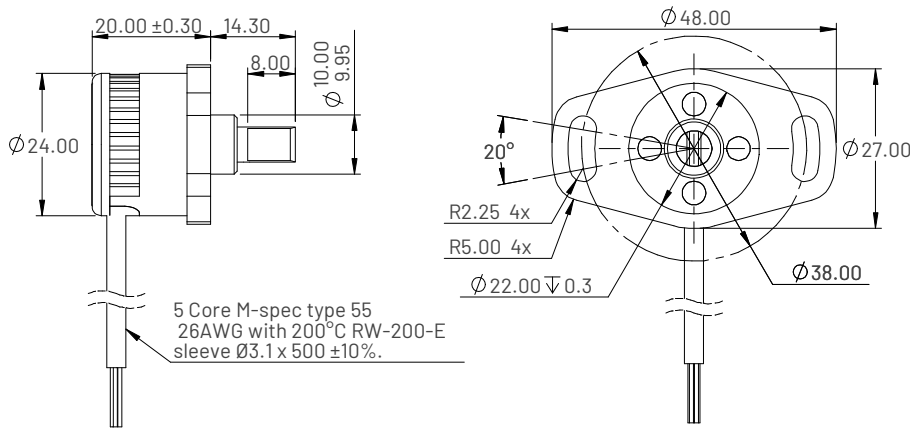

Drive shaft detail

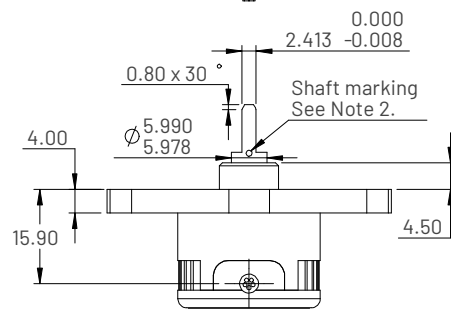
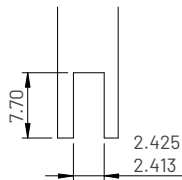

Ordering information

MHR513X CE

Heatshrink boot
 0 = Unbooted
 1 = Heatshrink boot
 Output direction (viewed on shaft)
 C = Clockwise

Electrical and mechanical specification for MHR5100 CE

Parameters	Values	Units
Input specification		
Supply voltage (Vs)	5.0±10% regulated 8 to 40 unregulated	VDC
Over voltage protection	Up to 50	VDC
Supply current	<15	mA
Reverse polarity protection	Up to -10	VDC
Power on settlement time	<100	ms
Input voltage rise time	0.25 minimum	V/ms
Output specification		
Output type	Digital	
Voltage output (Vout)	0-Vs (+5v) 0 - 5.0	VDC
Low level output	<0.4	VDC
High level output	>4.25	VDC
Load resistance	>10K	Ohms
Output noise	<5	mV RMS
Performance specification		
Pulses per revolution	512	
Dynamic angle error	Typical = 0.02, Max = 0.18	°
Max operating speed	14,500	RPM
General specification		
Weight (approx.)	30.0	grams
Protection/sealing	Electronic housing IP68 and IP69K	
Life (shaft in bush bearing)	>20 million cycles	dependent on environment
Dither life	Contactless - no degradation due to shaft dither	
Operational temperature	-40 to +125 See de-rating graph	°C
Storage temperature	-55 to +150	°C
Materials	Case: Glass filled polymer, Shaft: Stainless steel 316	
Max torque for fixing screw (M4 with washer)	1.8	Nm

MHR5100 CE Series - Magnetic-Hall rotary position sensor

General-purpose series, Encoder output

Notes

1. Incorrect wiring may cause internal damage.
2. Index pulse is aligned when shaft marking is facing cable exit.
3. Due to Hall effect technology used in this device, close proximity of ferrous materials and magnetic fields may influence output.

Electrical connections (see note 1)

Wire Colour	Function
Red	Supply Voltage (Vs)
Green	Channel A
Blue	Channel B
Yellow	Index
Black	Ground

Accessories

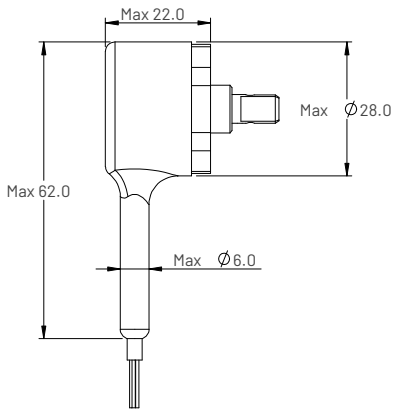

Boot
Part No: JN025-002

Material
Polyolefin

Input voltage de-rating graph

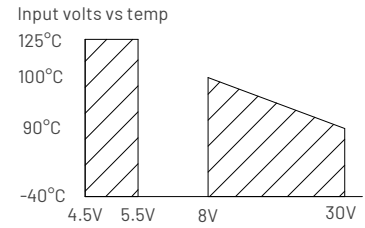

Typical output

